

HM082BKS

Group **U1**
Batteries

Snap-Top Battery Box™



Side View



Exploded View

Impact, UV, And Contaminant Resistant. Fully Ventilated To Release Gases.

All NOCO battery boxes meet US Coast Guard Code (USCG) of Federal Regulations.

Extremely rugged, structural reinforced battery boxes that provide uncompromising protection for any battery application. Manage your marine, RV, trailer, or stored batteries with ease of mind, knowing that the batteries are protected from any outside contaminants, and the internal reservoir makes sure anything on the inside, stays inside.

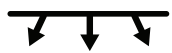

IMPACT
Resistant

Designed with an engineered polymer that maintains its impact properties down to -20 degrees Fahrenheit.

UV

Resistant

Designed with UV inhibitors and color stabilizers to prevent structure degradation, and color fading.

Made In
USA

We strive to create only the best. Every NOCO battery box is designed, engineered, and made in the USA.

Ventilated
SAFE
SECURE

Meets the USCG Code of Federal Regulations 183.420 and the ABYC's E-10.7 code requirements.

Snap-Top Battery Boxes Were Designed For Groups: U1, 24, 24-31, 27 & 6-Volt

The NOCO Company
30339 Diamond Parkway, #102
Glenwillow, OH 44139 | USA
1.800.456.6626

no.co

NOCO
Since 1914



Ventilation

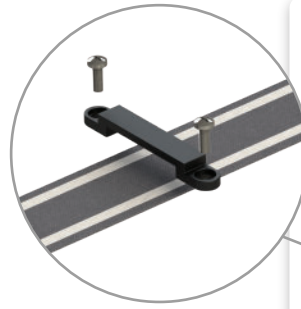

Battery Box Strap Kit
(Standard w/All Snap-Top)

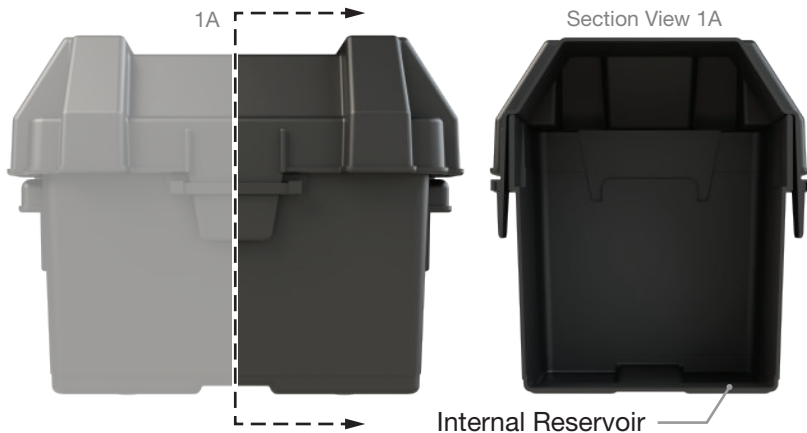

1A

Section View 1A

Internal Reservoir

Ventilation.

When a battery is presented with a high enough charge, the internal chemicals will begin to give off hydrogen gas. This gas can be dangerous when it is concentrated. NOCO's battery boxes all have proper ventilation, allowing for gases to escape.

Internal Reservoir.

Should there ever be an event where the structural integrity of the battery inside a NOCO battery box is weakened, the internal reservoir will collect any excess liquid, protecting the surrounding environment.

About Coast Guard Regulations.

The US Coast Guard maintains strict regulations on the storage of batteries. Batteries on-board boats must **not move more than one inch** in any direction surrounding the battery and only one inch in the vertical direction.

Battery Size Specifications

Min. Size: 6.0 (L) x 3.2 (W) x 5.0 (H) in.

Max. Size: 8.0 (L) x 5.2 (W) x 7.0 (H) in.

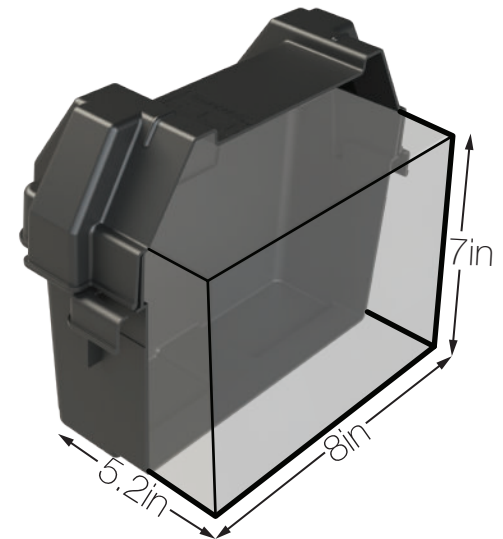
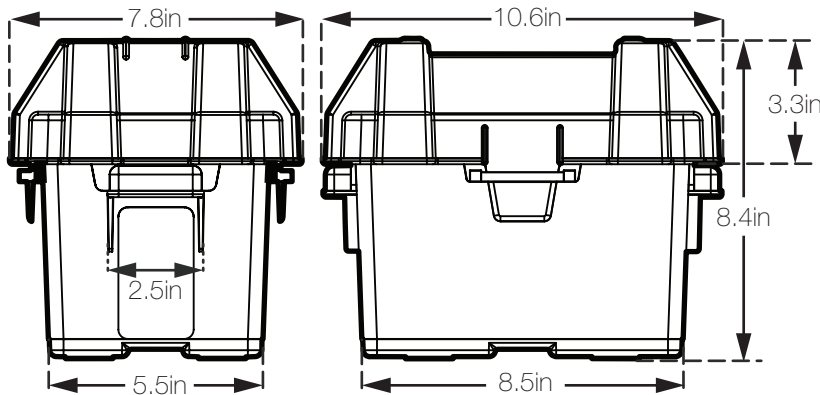

Internal capacity.

Technical Specifications

What's Included:	Battery Box, 42in. Strap, Hardware
Battery Size:	Group U1 Batteries
Internal Cargo Dimensions:	8.0 (L) x 5.2 (W) x 7.0 (H) in.
External Dimensions:	10.4 (L) x 7.2 (W) x 8.4 (H) in.
Product Weight:	1.9 lbs (30.4 oz)