

6 VOLT

BG6V



SNAP-TOP BATTERY BOX.

ULTIMATE PROTECTION.

IMPACT RESISTANT
DOWN TO -20°F.

RESISTANT TO
ACID, GAS, OIL, UV.



NOCO

30339 Diamond Parkway, #102
Glenwillow, OH 44139 | USA
1.800.456.6626

no.co

ALL NEW DESIGN.

**REINFORCED
STRUCTURE.**

**IMPROVED
LOCKING TABS.**

**HEAVY-DUTY
HANDLES.**

**EASY INSTALLATION.
MULTIPLE OPTIONS FOR INSTALLATION.**

OPTION 1: DIRECT MOUNT

Use predetermined mounting locations to fasten box directly to mounting surface.

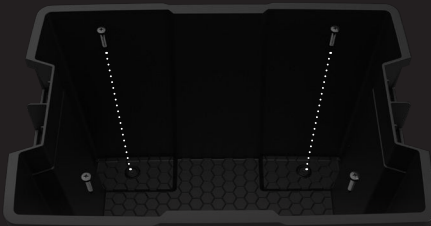

MAXIMUM VERSATILITY.

MULTIPLE CABLE PORTS.

Multiple cable ports offer easy installation for a variety of applications.

OPTION 2: STRAP MOUNT

STEP 1

Fasten mounting plate to desired location.

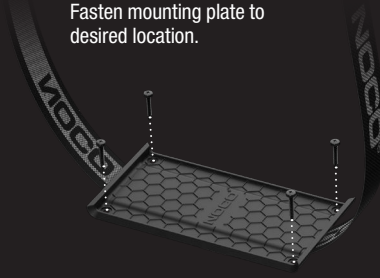

STEP 2

Use strap to fasten box to mounting tray.



WHAT'S IN THE BOX

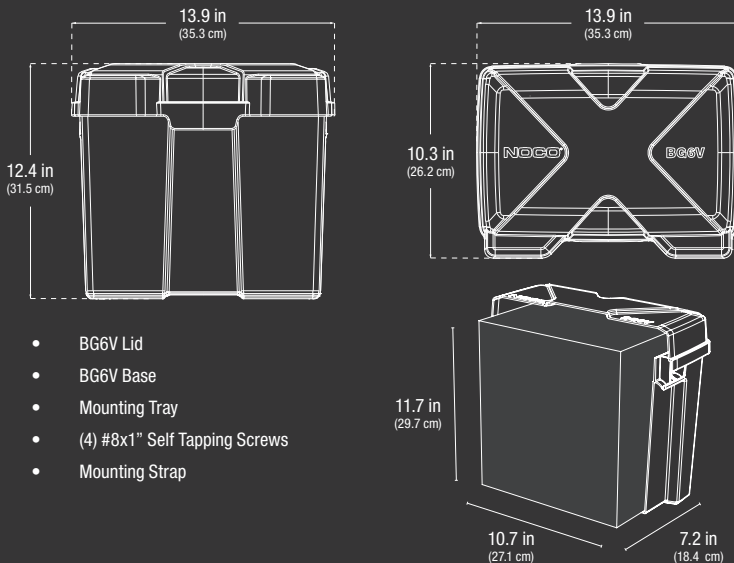

TECHNICAL SPECIFICATIONS

| | | | | | | | | | | | | | |
|---|---|--------------------------|-----------------------|---|---|------------------|-------------------|---------------------|-------------|--|---------------------|--|---------------------------------------|
| BATTERY GROUP: | 6 Volt Batteries | | | | | | | | | | | | |
| WEIGHT: | 2.94 lbs (1.33kg) | | | | | | | | | | | | |
| CERTIFICATIONS: | <ul style="list-style-type: none">• Meets Coast Guard (USCG) Code of Federal Regulations 183.420.• Meets American Boat and Yacht Council (ABYC) E-10.7. | | | | | | | | | | | | |
| VOLUMETRICS: | <table><tbody><tr><td>Retail Packaging:</td><td>Master Carton:</td></tr><tr><td>Dimensions: 13.90" x 10.30" x 12.40"</td><td>Dimensions: 14.13" x 10.50" x 35.00"</td></tr><tr><td>Weight: 3.10 lbs</td><td>Weight: 19.19 lbs</td></tr><tr><td>UPC: 00046221220087</td><td>Quantity: 6</td></tr><tr><td></td><td>UCC: 10046221220084</td></tr><tr><td></td><td>Units Per Pallet: 150 Units</td></tr></tbody></table> | Retail Packaging: | Master Carton: | Dimensions: 13.90" x 10.30" x 12.40" | Dimensions: 14.13" x 10.50" x 35.00" | Weight: 3.10 lbs | Weight: 19.19 lbs | UPC: 00046221220087 | Quantity: 6 | | UCC: 10046221220084 | | Units Per Pallet: 150 Units |
| Retail Packaging: | Master Carton: | | | | | | | | | | | | |
| Dimensions: 13.90" x 10.30" x 12.40" | Dimensions: 14.13" x 10.50" x 35.00" | | | | | | | | | | | | |
| Weight: 3.10 lbs | Weight: 19.19 lbs | | | | | | | | | | | | |
| UPC: 00046221220087 | Quantity: 6 | | | | | | | | | | | | |
| | UCC: 10046221220084 | | | | | | | | | | | | |
| | Units Per Pallet: 150 Units | | | | | | | | | | | | |

NOCO

30339 Diamond Parkway, #102
Glenwillow, OH 44139 | USA
1.800.456.6626

no.co